

REFUSE COLLECTION BODY (MICRO) SPECIFICATIONS RC06

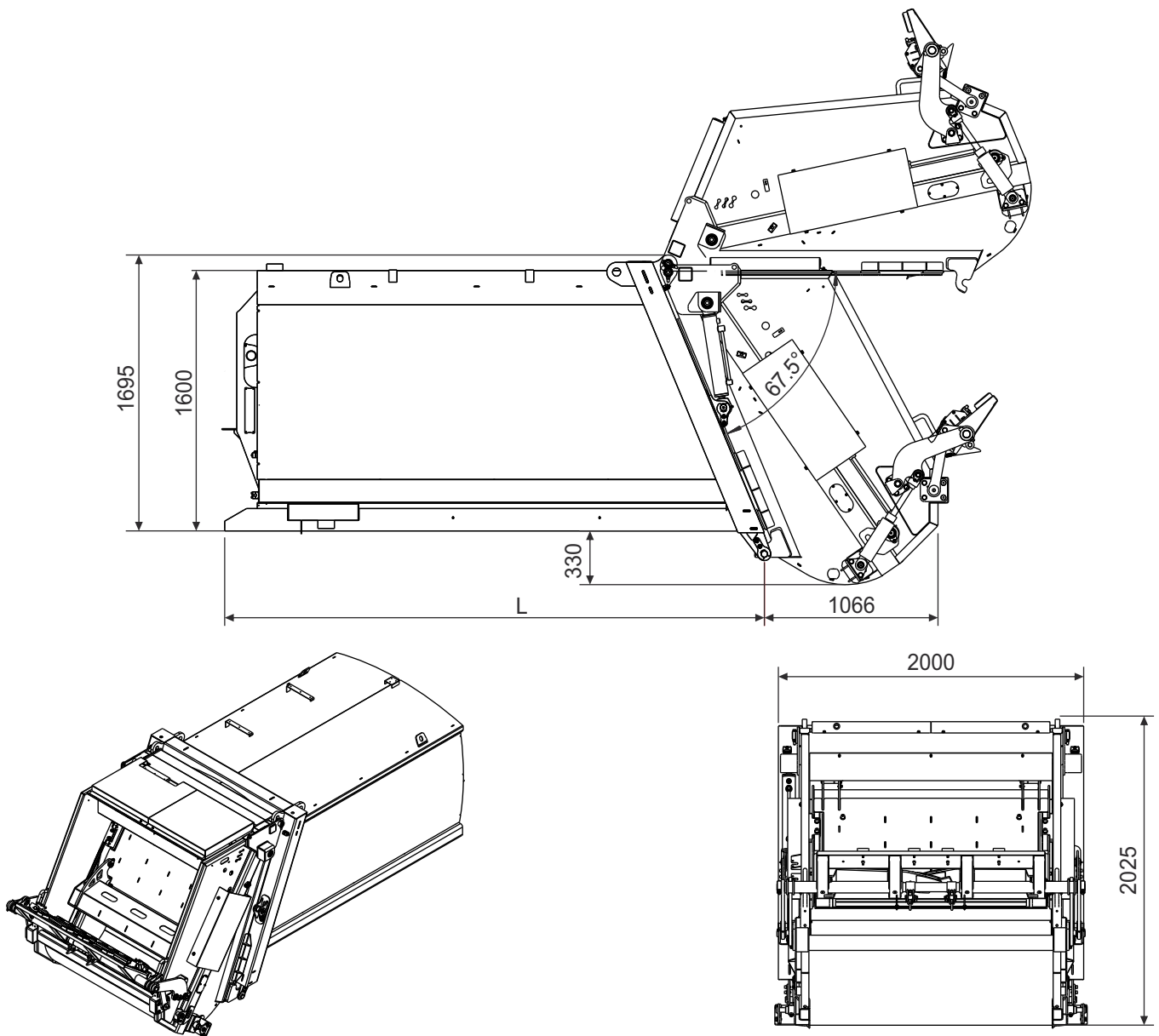

Description	RC0606	RC0607	RC0608
Container volume	6 m ³	07 m ³	08 m ³
Body length	3315 mm	3740 mm	4125 mm
Superstructure Weight*	2850 kg	3000 kg	3150 kg
Hopper Volume	0.6 m ³		
Operating System	Entry-M (manual), Entry-E (electrical)		
Compaction cycle time**	18 sec		
Tailgate Lifting Time	17 sec		
Est. Discharging time	17 sec	20 sec	23 sec
Est. Payload	3600-4500 kg	4200-5250 kg	4800-6000 kg
Electric Power	24 V		
Bin lifter capacity (wide comb)	600 kg		
Bin lifter lifting cycle time (up and down) (wide comb)	12 sec		

*Weight includes steel structure, hydraulic parts, electrical parts and bin lift
 **Cycle time calculated with 50 lpm flow