

# HYVA GEAR PUMPS



Hyva

gear pump type :

gear pump 082L - BI - 4H5 - 4P

page # 1 / 2

part number :

145 62 325

rotation :

bi-rotational

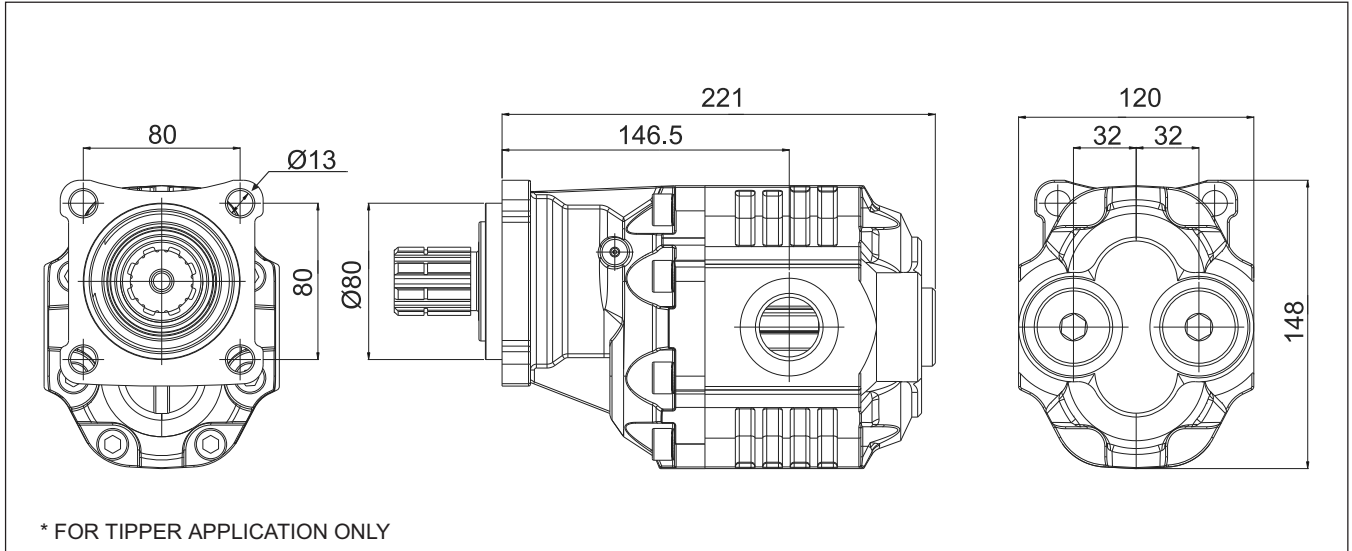

\* FOR TIPPER APPLICATION ONLY

## specifications

displacement per revolution	:	81,68	cm <sup>3</sup>
maximum peak pressure	:	230	bar
maximum intermittent pressure	:	225	bar
maximum continuous pressure	:	205	bar
maximum speed without load	:		min <sup>-1</sup>
max. speed at intermittent press.	:	2500	min <sup>-1</sup>
min. speed at intermittent press.	:	300	min <sup>-1</sup>
oil temperature range	:	-25⇄80	°C
inlet pressure range (suction side)	:	0.7⇄3	bar (abs)
recommended oil viscosity range	:	12⇄100	mm <sup>2</sup> /s (cSt)
maximum starting viscosity	:	750	mm <sup>2</sup> /s (cSt)
filtration :			
- working pressure < 200 bar	:	25	µm
- working pressure > 200 bar	:	10	µm
connection :			
- inlet - straight internal thread	:	1	" B.S.P.
- outlet - straight internal thread	:	1	" B.S.P.
minimum suction hose bore diameter	:	1,75	inch
shaft DIN 5462	:	8*32*36	mm
mass	:	+/-15	kg

efficiency diagram on request

## pressure definition

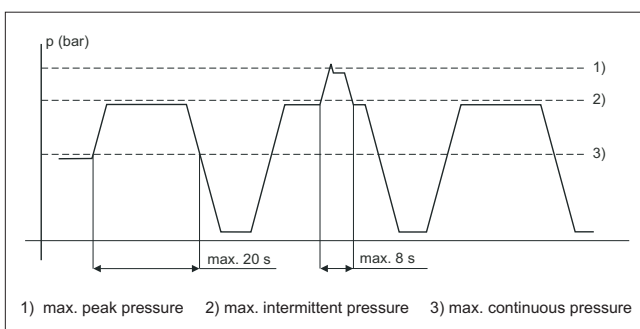

## power and torque

Pressure (bar)	50	100	150	200	225
Torque (Nm)	75	142	205	266	294
Power (kW)					
500	4	7	11	14	15
1000	8	15	21	28	31
1500	12	22	32	42	46
2000	16	30	43	56	62
2500	20	37	54	70	77
Flow (L/min.)					
500	39	39	38	38	38
1000	79	77	76	75	75
1500	118	116	114	113	113
2000	157	154	152	151	151
2500	196	193	190	189	188

## hydraulic pump symbol

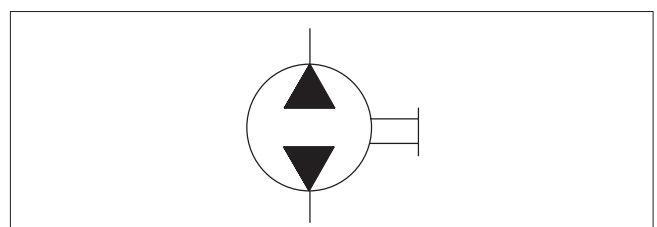

Hyva	gear pump type :	gear pump 082L - BI - 4H5 - P4
page # 2 / 2	part number :	145 62 325
	rotation :	bi-rotational

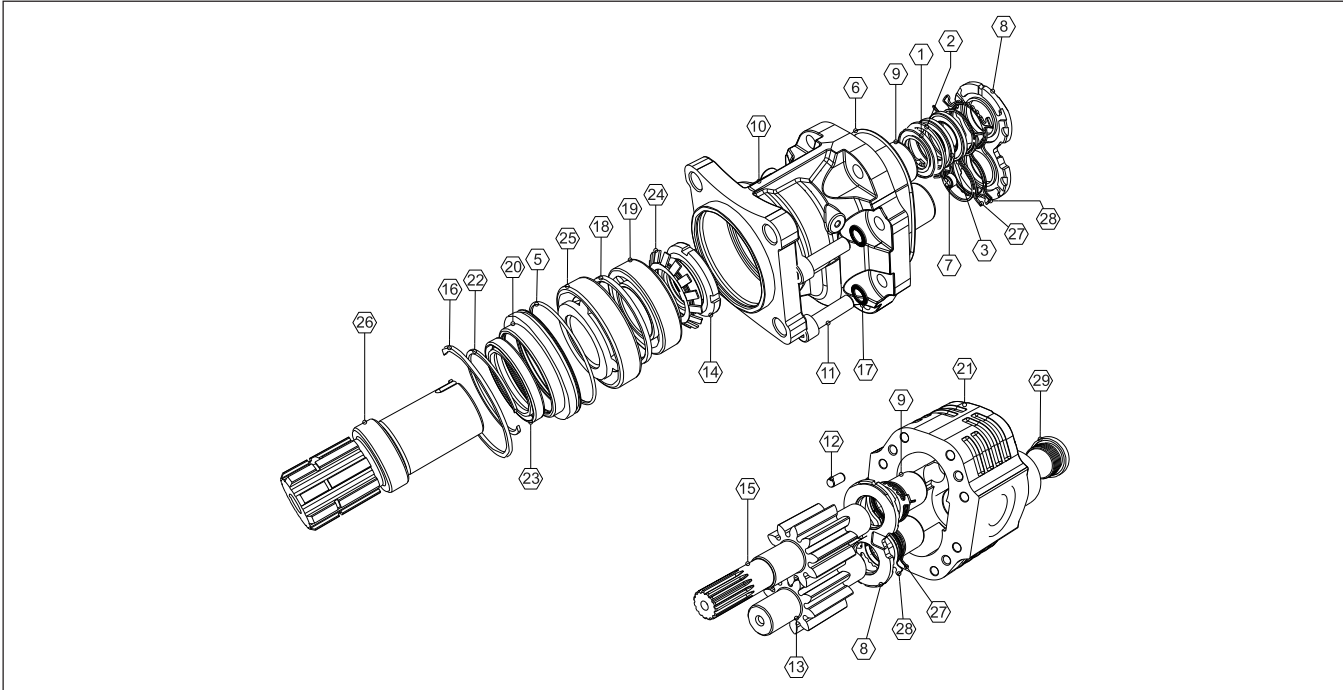

## spare part list gear pump 145 62 325

pos.	code no.	description	qty.
1	145 62 325-01	Oil seal	1
2	145 62 325-02	Circlip	1
3	145 62 325-03	Oil seal	2
4		not shown	
5	145 62 325-05	O-ring	1
6	145 62 325-06	O-ring	1
7	145 62 325-07	Check valve	2
8	022 59 430	Thrust plate	2
9	145 62 325-09	Bearing	4
10	145 62 325-10	Front housing	1
11	145 62 325-11	Bolt	8
12	145 62 325-12	Centring pin	4
13	145 62 325-13	Driven gearwheel	1
14	145 62 325-14	Locking ring	1
15	145 62 325-15	Driving gearwheel	1
16	145 62 325-16	Spring ring	1
17	145 62 325-17	Nordlock washer	8
18	145 62 325-18	Spacer ring	1
19	145 62 325-19	Bearing	1
20	145 62 325-20	Support ring	1
21	145 62 325-21	Rear housing	1
22	145 62 325-22	Spring ring	1
23	145 62 325-23	Oil seal	1
24	145 62 325-24	Spring washer	1
25	145 62 325-25	Bearing	1
26	145 62 325-26	Front shaft	1
27	145 62 325-27	Anti-extrusion ring	2
28	145 62 325-28	Thrust plate seal	2
29	145 62 325-29	Plug BSP	2

## seal kit

code no.	description	qty.
146 00 100	seal kit complete (comprises 1, 3, 5, 6, 23, 27 & 28)	1

## general information and mounting possibilities.

The mentioned data on page 1 is for mineral based oil.  
For other fluids, please contact our engineering dept.

The filtration as mentioned is for tippers only. For different applications we advise filtration according ISO 4406 class 17/14.

To avoid cavitation, the suction hose must be kept as short and straight as possible, and the minimum oil level in the oil tank must be above the inlet of the pump.

Side and/or rear ports can be used as desired.

Torque plugs:

3/4"	60 Nm
1"	75 Nm
1 1/4"	115 Nm