

* incl. 20 [-5; +30] mm pull out

3D model is available on request or www.hyva.com

Specifications		Max. pump flow		Tipping time	
Max. working pressure	150 bar	With KO ¹	190 L/min	With KO ¹	46 sec
Weight	361 kg	Without KO ¹	170 L/min	Without KO ¹	52 sec
Working volume	147 L	With KO ¹ below -20°C	133 L/min	With KO ¹ below -20°C	66 sec
Total volume	158 L	Without KO ¹ below -20°C	119 L/min	Without KO ¹ below -20°C	74 sec
Max. cyl. load (start tipping)	440 kN			Allowable lowering time	46 sec
Max. cyl. load (end of stroke) ²	145 kN				
Max. cyl. load (end of stroke) ³	169 kN				

Technical notes

- This cylinder is a lifting device only. • It should not be used as a structural member and should not be subjected to side loads. • Tipping valve must have a pressure relief at the cylinder port set not higher than max. working pressure. • Verify max. cyl. load. • Working temperature range is between -40°C and +80°C. • Max. duration of extension is 0.5 hours (excluded hard chromed stages). • Cylinder is painted black (RAL9005) with a min. thickness conforming to the 480 hours neutral salt spray test as per ISO 9227. • ¹ Hyva knock-off. • ² Unsubstantial unloading (sticky load). • ³ Substantial unloading.

Related documentation

- Bracket options: 015BRA10 & 015BRA13
- Mounting instructions: CYL-0031
- Oil specifications: OIL-0011
- Spec sheet explanation: CYL-0041

Configuration

Extension	1	2	3	4	5	6	7	Total
Effective diameter [mm]	191	169	149	129				7220
Stroke* [mm]	1790	1810	1810	1810				

Tipping weight

For detailed tipping calculations please refer to: <https://tipper.hyva.com>

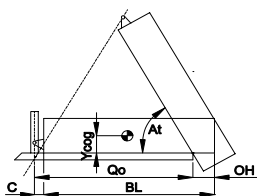

- BL body length
 - OH rear overhang
 - Ycog vert. pos. centre of gravity
 - Qo pivot length
 - C bracket length
 - At tipping angle
- $stroke \times 60 / Qo$

BL [mm]	9500			9300			9100		
OH [mm]	200	500	800	200	500	800	200	500	800
At [°]	46	47	49	47	49	50	48	50	52
Ycog [mm]									
600	51	54	57	51	55	58	52	55	60
900	53	57	61	54	58	63	55	59	64
1200	56	60	66	57	62	67	58	63	69

Tipping weight [ton] at maximum pressure of 150 bar for a vertically mounted cylinder and C is 158 mm

Pos.	Part no.	Description	Qty.
C01	71839133	DUST COVER FE 179-4/191-4	1
P01	74464871	PISTON FL3 S 129-2095-HC	1
P02	71853129K	SLIDER FL 129 (2 X 1/2) A22	1
P03	71851129K	OUTER STOPRING FL 129 A22	1
P04	71822129	BOTTOM PLATE PISTON FL 129	1
P05	01745052K	CIRCLIP 120 DIN 472 (127.0x4.0)	1
P06	71870225K	O-RING PISTON BOTTOM 129	1
P07	71847400	PISTON EYE SPH. FL3 129 L=075 B=60	1
P08	71870125K	O-RING 110.72 X 3.53 MM	1
P09	71875460K	SPHERICAL BEARING D.60.3 MAINT. FREE	1
P10	01770580K	CIRCLIP 90 DIN 472 (95.5x3.5)	1
P11	71875012	PIN ROUND HEAD GROOVED 8x15 mm	2

S31	74605871	STAGE FL2 149-2090-HC	1
S32	71802149K	PACKSET FL 149/HP 150	1
S33	71807151K	SLIDER FL 149 A35	1
S34	71851149K	OUTER STOPRING FL 149 A22	1
S35	71852149K	LIFTRING FL 149 A22	1

S21	74606871	STAGE FL2 169-2090-HC	1
S22	71802169K	PACKSET FL 169	1
S23	71807171K	SLIDER FL 169 A35	1
S24	71851169K	OUTER STOPRING FL 169 A22	1
S25	71813169K	LIFTRING FL 169x5	1

S11	74607871	STAGE FL2 191-2090-HC	1
S12	71802191K	PACKSET FL 191	1
S13	71807193K	SLIDER FL 191 A35	1
S14	71851191K	OUTER STOPRING FL 191 A22	1
S15	71813191K	LIFTRING FL 191x5	1

B01	74508874	BASE FL2 214-2141-4/4BSAE-290	1
B02	71802214K	PACKSET FL 214	1
B03	71825435	BOTTOM PLATE FL2 214	1
B04	71870045K	SEAL BOTTOM PLATE FL 214	1
B05	71820214	LOCKING PLATE FL 214	3
B06	01732020K	BOLT HEX M12X25X1.25 SET 6 PCS	1
B07	01732523K	WASHER SPRING M12 SET 6 PCS	1

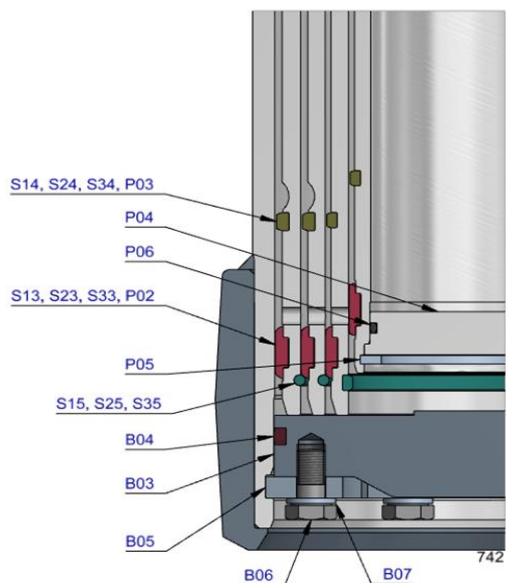
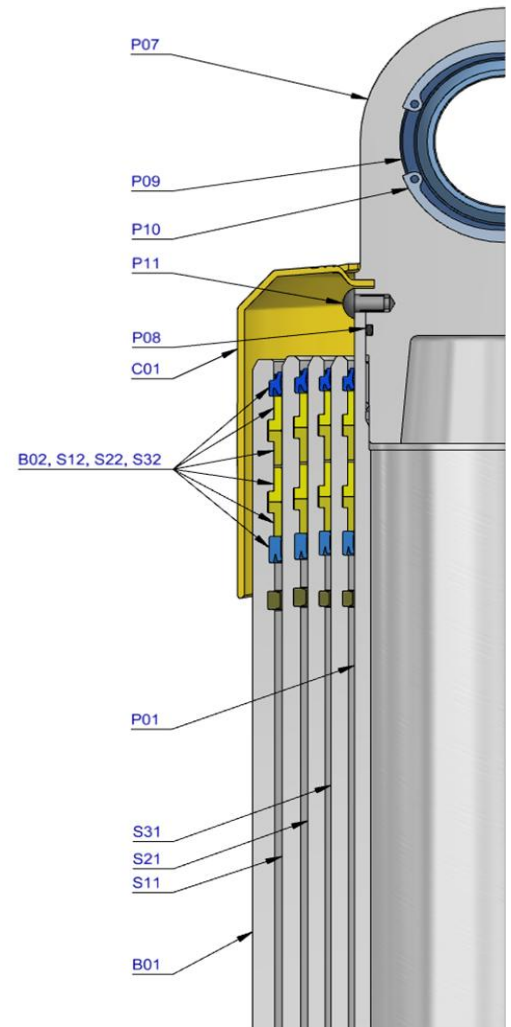

Seal kit complete

71908740K	Consists of all packsets with packset grease and O-rings
-----------	--

Notes

The inner stopring and piston bottom are pre-mounted on spare bases, stage and pistons. Therefore, when ordering new tubes, it is not required to order these parts separately.

For repair instructions see: CYL-0040. Serial no. is located on type plate and near type plate support.