

HYVA CYLINDER



715 06 580

Front end cylinder with outer cover

type

FC 169-5-07130-000A-K0343

tipping weight

34-50 ton

page # 1 / 2

closed length (K)

338-373 mm

front & side view cylinder

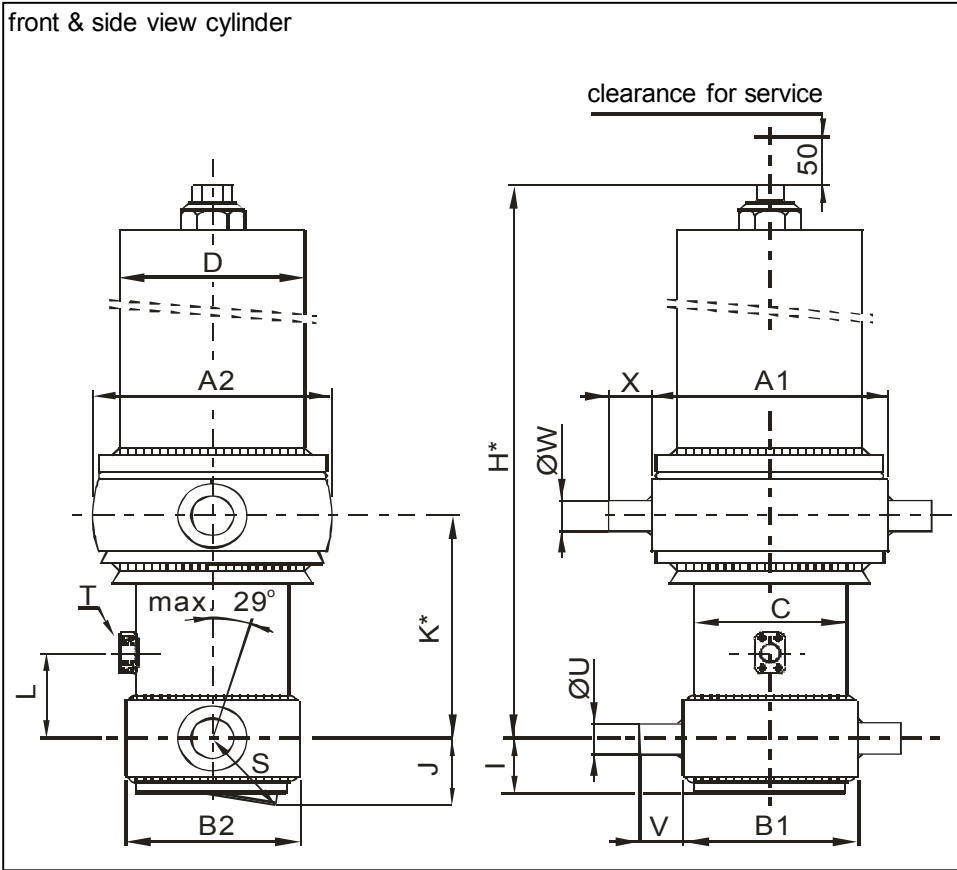

	1	2	
A	340	329	mm
B	245	224	mm
C	191		mm
D	242		mm
E			mm
F			mm
G*			mm
H*	1769		mm
I	65		mm
J	106		mm
K*	343		mm
L	190		mm
M*			mm
N			mm
O			mm
P			mm
Q			mm
R			mm
S	127		mm
T	1" SAE		
U	60		mm
V	65		mm
W	60		mm
X	65		mm
Y			mm
Z			mm

*incl.20[-5;30] pull out on piston

specifications

weight cylinder only	351 kg
total volume	107 L
working volume	99 L
maximum pressure	190 bar
maximum pump flow	137 L/min
maximum cylinder angle to front	10 °
maximum thrust first stage**	35 ton

**when cyl. mounted at a large angle, thrust first stage may become too high: see Hyva Tipper Program

technical notes

This cylinder is a lifting device only and may not be used as structural member or be subject to side load. Working pressure depends on application; never exceed maximum pressure stated.

Cylinder is painted black (RAL9005).

Max duration of extension 0.5 hours (excluded HC). See specification sheet CYL-0019 for mounting instructions, OIL-0011 for oil specifications and 015BRA01 for bracket specifications.

extension	1	2	3	4	5	6	7	8	9	
effective diameter [mm]	169	149	129	110	91					total
stroke [mm]	1410	1430	1430	1430	1430					7130

tipping weight

tipping weight at maximum pressure of 190 bar and C is 229 mm

BL (body length); OH (rear overhang); X=Ycog (vert. pos. centre of gravity); Qo (pivot length); C (bracket length); At = stroke x 60 / Qo	BL	9500			9150			8800		
	OH	200	500	800	200	500	800	200	500	800
At	44	46	47	46	48	49	48	50	52	
Ycog										
600	34	36	38	34	37	40	35	38	41	
900	35	38	41	36	39	43	38	41	45	
1200	37	40	44	39	42	46	40	44	50	

HYVA CYLINDER

715 06 580



Front end cylinder with outer cover

page # 2 / 2

type

FC 169-5-07130-000A-K0343

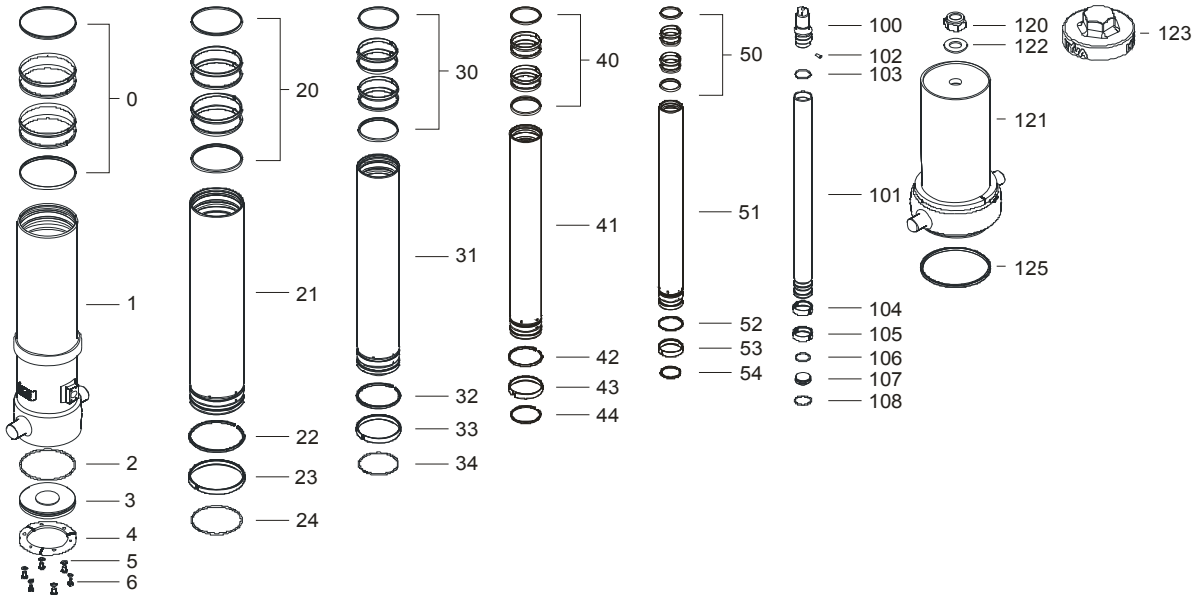

Spare part list

Pos	Part no.	Description	Qty.
0	71802191 K	PACKSET FL 191	01
1	72507650R1345	BASE 191-1689-4/4SAE-190-C242	01
2	71870040 K	SEAL BOTTOM PLATE 191	01
3	71821191	BOTTOM PLATE 191	01
4	71820191	LOCKING PLATE 191	03
5	01732559 K	SPRING WASHER M8 SET	01
6	01732055 K	BOLT M8 X 1.25 X 20 SET	01

20	71802169 K	PACKSET FL 169	01
21	72606650	STAGE 169-1650	01
22	71811169 K	OUTER STOPRING FL 169	01
23	71807169 K	SLIDER FL 169	01
24	71813169 K	LIFTRING FL 169x5	01

30	71802149 K	PACKSET FL 149/HP 150	01
31	72605650	STAGE 149-1650	01
32	71811149 K	OUTER STOPRING FL 149	01
33	71807149 K	SLIDER FL 149	01
34	71812149 K	LIFTRING FL 149/HP 150	01

40	71802129 K	PACKSET FL 129/HP 129	01
41	72604650	STAGE 129-1650	01
42	71811129 K	OUTER STOPRING FL 129/HP 129 HD	01
43	71807129 K	SLIDER FL 129/GF 129 (2 X 1/2)	01
44	71812129 K	LIFTRING FL 129/HP 129	01

Seal kit complete:

Part no.	Description
71901650 K	Seal kit complete: consists of all packsets with packset grease, O-rings and Pin (pos.102)

Spare part list

Pos	Part no.	Description	Qty.
50	71802110 K	PACKSET FL 110	01
51	72603650	STAGE 110-1650	01
52	71811110 K	OUTER STOPRING FL 110/HP 110 HD	01
53	71807110 K	SLIDER FL 110/GF 110 (2 X 1/2)	01
54	71812110 K	LIFTRING FL 110	01

100	71831091	PISTON HEAD 091 MACHINED	01
101	72402651	PISTON S 091-1655-HC	01
102			
103	71870115 K	O-RING PISTON TOP 091	01
104	71811091 K	OUTER STOPRING FL 091/HP 091 HD	01
105	71807091 K	SLIDER FL 091 (2 X 1/2)	01
106	71870215	O-RING PISTON BOTTOM 091	01
107	71822091	BOTTOM PLATE PISTON 091	01
108	01745012	CIRCLIP 82 DIN 472 (87.5x2.5)	01

120	01702907	TOPNUT NYLOC M48x3 DIN 985 ZP	01
121	71706632	COVER 242-1445 PIN60	01
122	01702956	WASHER M48 DIN 125B ZP	01
123	01702972	DUST COVER FOR COVER 242 YELLOW	01
125	01791941	O-RING COVER D242	01

Notes:

The inner and outer stoprings are pre-mounted in the grooves on spare stages and pistons. Therefore, when ordering new tubes, it is not required to order stopring separately.