

* incl. 20 [-5; +30] mm pull out

3D model is available on request or www.hyva.com

Specifications	Max. pump flow		Tipping time		
Max. working pressure	220 bar	With KO ¹	190 L/min	With KO ¹	47 sec
Weight	468 kg	Without KO ¹	170 L/min	Without KO ¹	52 sec
Working volume	148 L	With KO ¹ below -20°C	133 L/min	With KO ¹ below -20°C	67 sec
Total volume	159 L	Without KO ¹ below -20°C	119 L/min	Without KO ¹ below -20°C	74 sec
Max. cyl. load (start tipping)	345 kN			Allowable lowering time	47 sec
Max. cyl. load (end of stroke) ²	150 kN				
Max. cyl. load (end of stroke) ³	175 kN				

Technical notes

- This cylinder is a lifting device only.
- It should not be used as a structural member and should not be subjected to side loads.
- Tipping valve must have a pressure relief at the cylinder port set not higher than max. working pressure.
- Verify max. cyl. load.
- Working temperature range is between -40°C and +80°C.
- Max. duration of extension is 0.5 hours (excluded hard chromed stages).
- Cylinder is painted black (RAL9005) with a min. thickness conforming to the 480 hours neutral salt spray test as per ISO 9227.
- ¹ Hyva knock-off.
- ² Unsubstantial unloading (sticky load).
- ³ Substantial unloading.

Related documentation

Bracket options:	015BRA10 & 015BRA12
Mounting instructions:	CYL-0030
Oil specifications:	OIL-0011
Spec sheet explanation:	CYL-0041

Configuration

Extension	1	2	3	4	5	6	7	Total
Effective diameter [mm]	191	169	149	129	110			8130
Stroke* [mm]	1610	1630	1630	1630	1630			

Tipping weight

For detailed tipping calculations please refer to: <https://tipper.hyva.com>

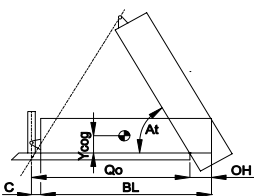

BL body length
OH rear overhang
Ycog vert. pos. centre of gravity
Qo pivot length
C bracket length
At tipping angle
stroke x 60 / Qo

BL [mm]	10800			10350			9900		
OH [mm]	200	500	800	200	500	800	200	500	800
At [°]	44	46	47	46	48	49	49	50	52
Ycog [mm]									
600	56	59	62	57	61	65	59	63	67
900	59	62	66	60	64	69	63	67	73
1200	61	65	70	64	68	74	67	72	79

Tipping weight [ton] at maximum pressure of 220 bar for a vertically mounted cylinder and C is 229 mm

Pos.	Part no.	Description	Qty.
C01	71839050	DUST COVER FC LOW 15-273	1
C02	71737793	COVER 273-1685 PIN60 A360 SPH LOCK	1
C03	01702956K	WASHER M48 DIN 125B ZP	1
C04	01702907K	TOPNUT NYLOC M48x3 DIN 985 ZP	1
C05	01791953	O-RING COVER D.273	1
C06	15014550K	BOLT HSHC M12X30X1.75 Q8.8 DIN 912 ZP	1
P01	74463771	PISTON FL3 S 110-1885-HC	1
P02	71853110K	SLIDER FL 110 (2 X 1/2) A22	1
P03	71851110K	OUTER STOPRING FL 110 A22	1
P04	71822110	BOTTOM PLATE PISTON FL 110	1
P05	01745050K	CIRCLIP 100 DIN 472 (105.5x3.0)	1
P06	71870220K	O-RING PISTON BOTTOM 110	1
P07	71848300	PISTON HEAD FL3 110	1
P08	01226538K	O-RING 91.67 X 3.53 MM NBR	1

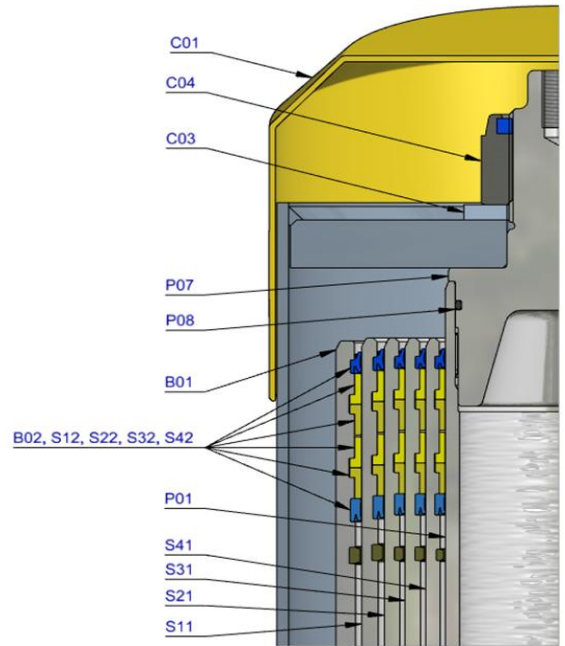

S41	74604771	STAGE FL2 129-1880-HC	1
S42	71802129K	PACKSET FL 129/HP 129	1
S43	71853129K	SLIDER FL 129 (2 X 1/2) A22	1
S44	71851129K	OUTER STOPRING FL 129 A22	1
S45	71852129K	LIFTRING FL 129 A22	1

S31	74605771	STAGE FL2 149-1880-HC	1
S32	71802149K	PACKSET FL 149/HP 150	1
S33	71807151K	SLIDER FL 149 A35	1
S34	71851149K	OUTER STOPRING FL 149 A22	1
S35	71852149K	LIFTRING FL 149 A22	1

S21	74606771	STAGE FL2 169-1880-HC	1
S22	71802169K	PACKSET FL 169	1
S23	71807171K	SLIDER FL 169 A35	1
S24	71851169K	OUTER STOPRING FL 169 A22	1
S25	71813169K	LIFTRING FL 169x5	1

S11	74607771	STAGE FL2 191-1880-HC	1
S12	71802191K	PACKSET FL 191	1
S13	71807193K	SLIDER FL 191 A35	1
S14	71851191K	OUTER STOPRING FL 191 A22	1
S15	71813191K	LIFTRING FL 191x5	1

B01	74508770R1585	BASE FL2 214-1931-4/4BSAE-190-C273	1
B02	71802214K	PACKSET FL 214	1
B03	71825435	BOTTOM PLATE FL2 214	1
B04	71870045K	SEAL BOTTOM PLATE FL 214	1
B05	71820214	LOCKING PLATE FL 214	3
B06	01732020K	BOLT HEX M12X25X1.25 SET 6 PCS	1
B07	01732523K	WASHER SPRING M12 SET 6 PCS	1

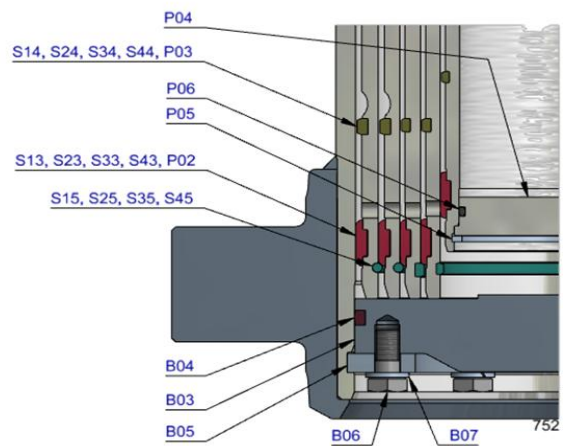
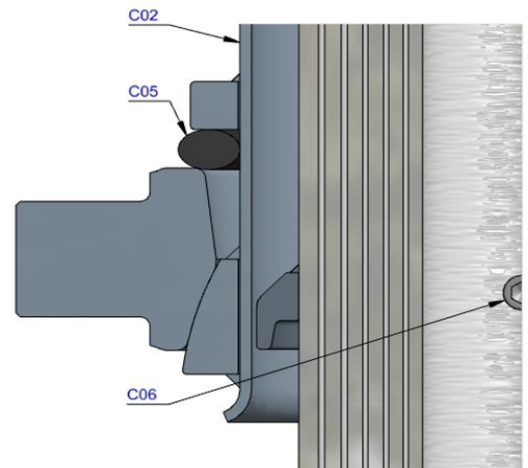

Seal kit complete

71908750K	Consists of all packsets with packset grease and O-rings
-----------	--

Notes

The inner stopring and piston bottom are pre-mounted on spare bases, stage and pistons. Therefore, when ordering new tubes, it is not required to order these parts separately.

For repair instructions see: CYL-0040. Serial no. is located on type plate and near type plate support.