

* incl. 20 [-5; +30] mm pull out

3D model is available on request or www.hyva.com

Specifications		Max. pump flow		Tipping time	
Max. working pressure	250 bar	With KO ¹	122 L/min	With KO ¹	11 sec
Weight	130 kg	Without KO ¹	86 L/min	Without KO ¹	15 sec
Working volume	22 L	With KO ¹ below -20°C	85 L/min	With KO ¹ below -20°C	16 sec
Total volume	24 L	Without KO ¹ below -20°C	60 L/min	Without KO ¹ below -20°C	21 sec
Max. cyl. load (start tipping)	195 kN			Allowable lowering time	11 sec
Max. cyl. load (end of stroke) ²	185 kN				
Max. cyl. load (end of stroke) ³	195 kN				

Technical notes

- This cylinder is a lifting device only. • It should not be used as a structural member and should not be subjected to side loads. • Tipping valve must have a pressure relief at the cylinder port set not higher than max. working pressure. • Verify max. cyl. load. • Working temperature range is between -40°C and +80°C. • Max. duration of extension is 0.5 hours (excluded hard chromed stages). • Cylinder is painted black (RAL9005) with a min. thickness conforming to the 480 hours neutral salt spray test as per ISO 9227. • ¹ Hyva knock-off. • ² Unsubstantial unloading (sticky load). • ³ Substantial unloading.

Related documentation

Bracket options:	015BRA10 & 015BRA12
Mounting instructions:	CYL-0030
Oil specifications:	OIL-0011
Spec sheet explanation:	CYL-0041

Configuration

Extension	1	2	3	4	5	6	7	Total
Effective diameter [mm]	110	91	72					3235
Stroke* [mm]	1065	1085	1085					

Tipping weight

For detailed tipping calculations please refer to: <https://tipper.hyva.com>

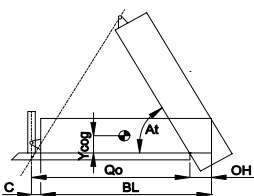

BL body length
OH rear overhang
Ycog vert. pos. centre
of gravity
Qo pivot length
C bracket length
At tipping angle
stroke x 60 / Qo

BL [mm]	4400	4150	3900			
OH [mm]	400	400	400	200	200	200
At [°]	600	600	600	47	49	52
Ycog [mm]	44	46	48	47	49	52
Qo [mm]	200	200	200	200	200	200
C [mm]	44	46	48	47	49	52
At [°]	44	46	48	47	49	52
	28	31	34	29	32	36
	31	34	39	32	37	44
	34	39	47	37	44	41

Tipping weight [ton] at maximum pressure of 250 bar for a vertically mounted cylinder and C is 178 mm

Pos.	Part no.	Description	Qty.
C01	71839000	DUST COVER FC LOW 15-168	1
C02	71703326	COVER 168-1035 PIN60 A201 FIX	1
C03	01702956K	WASHER M48 DIN 125B ZP	1
C04	01702907K	TOPNUT NYLOC M48x3 DIN 985 ZP	1
P01	74461301	PISTON FL3 S 072-1280-HC	1
P02	71853072K	SLIDER FL 072 (2 X 1/2) A22	2
P04	71822072	BOTTOM PLATE PISTON FL 072	1
P05	01745026K	CIRCLIP 63 DIN 472 (67.2x2.0)	1
P06	71870210K	O-RING PISTON BOTTOM 072	1
P07	71848100	PISTON HEAD FL3 072	1
P08	01226420K	O-RING 53.57 X 3.53 MM	1

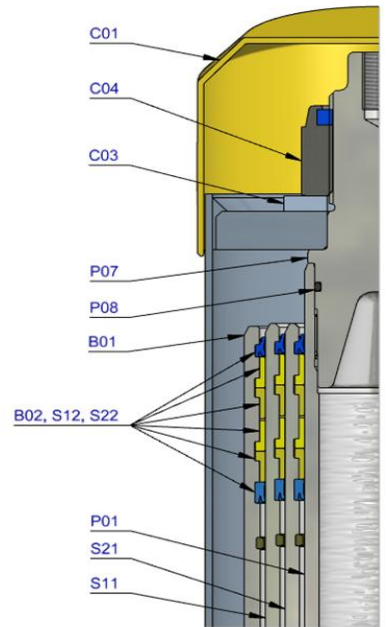

S21	74602301	STAGE FL2 091-1275-HC	1
S22	71802091K	PACKSET FL 091	1
S23	71853091K	SLIDER FL 091 (2 X 1/2) A22	1
S24	71851091K	OUTER STOPRING FL 091 A22	1
S25	71852091K	LIFTRING FL 091 A22	1
S11	74603301	STAGE FL2 110-1275-HC	1
S12	71802110K	PACKSET FL 110	1
S13	71853110K	SLIDER FL 110 (2 X 1/2) A22	1
S14	71851110K	OUTER STOPRING FL 110 A22	1
S15	71852110K	LIFTRING FL 110 A22	1
B01	74504300R0935	BASE FL2 129-1314-4/4BSAE-190-C168	1
B02	71802129K	PACKSET FL 129/HP 129	1
B03	71825415	BOTTOM PLATE FL2 129	1
B04	71870025K	O-RING BOTTOM PLATE FL 129	1
B05	71820129	LOCKING PLATE FL 129	3
B06	01732055K	BOLT HEX M8X20X1.25 SET 3 PCS	1
B07	01732559K	WASHER SPRING M8 SET 3 PCS	1

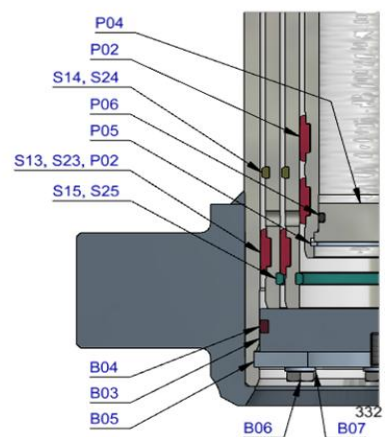
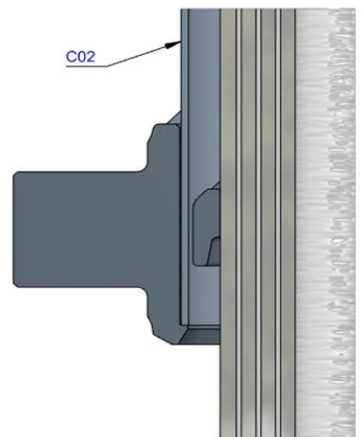

Seal kit complete

71908330K	Consists of all packsets with packset grease and O-rings
-----------	--

Notes

The inner stopring and piston bottom are pre-mounted on spare bases, stage and pistons. Therefore, when ordering new tubes, it is not required to order these parts separately.

For repair instructions see: CYL-0040. Serial no. is located on type plate and near type plate support.